

CLASSIC CARGOMASTER MODEL HT

8,000lbs (35.6kn) to 10,000lbs (44.5kN) Drawbar pull

For more information on Equipment and Parts go to www.harlan-corp.com or contact our sales group at 800-255-4262 or 913-342-5650 Ext. 205 Email: sales@harlan-corp.com



above photos shown with options

RUGGED ... DURABLE ... HARLAN

The Harlan Classic Cargomaster Model HT is available with the latest tier rated Diesel, Gasoline and LPG engines. This heavy-duty classic model will last for years! Designed for heavy-duty cargo and for baggage applications, this unit can also be utilized for pushback of small aircraft (with front hitch option package). Some options include complete cab assembly, heat/defrost, mirrors, beacons, variety of hitches and suspension style seats. (Additional options are available.)

STANDARD FEATURES



ISO Certified since 2001

Since 1962 when Jim Kaplan founded Harlan, the Kansas City based company has been manufacturing, supporting and supplying some of the finest GSE, OEM & Aftermarket Parts in the industry.

- F-N-R Shifter
- Keyless anti-restart ignition switch
- Two Headlights
- Combination Tail/Stop lights & Back-up light
- Volt Meter
- Water Temperature Gauge
- Engine Oil Pressure Gauge
- Engine Hour Meter
- Fuel Level Gauge
- Standard Driver and Passenger seat
- Retractable Seatbelts
- Rear mount three-tier hitch (other hitch options available)

Today, Harlan Global Manufacturing has multiple manufacturing, supply chain, and support offices around the world. Let Harlan be your manufacturing partner.



Scan with your smartphone app for instant access to our website!

DETAILED FEATURES AND OPTIONS AVAILABLE ON-LINE at www.harlan-corp.com

Model HT (8,000lb and 10,000lb) Drawbar Pull (35.6kN to 44.5kN)

TECHNICAL SPECIFICATIONS

Specifications are subject to improvement and/or change without notice

| Model | HT80 | | HT100 | |
|--|---------------------------------------|------------------------------|--|---|
| DBP | 8000 lbs (35.6 kN) | | 10000 lbs (44.5 kN) | |
| Length | Width | Height | Wheel Base | Ground Clearance |
| 115.75 (2941 mm) | 66" (1676 mm) | 61" (1549 mm) | 67.75" (1721 mm) | 5" (127 mm) |
| with rear hitch: 124.75" (3170 mm) | | with cab: 83" (2108 mm) | | |
| Drive Axle | Steer Axle | Suspension | Towing Coupler | Tires |
| Heavy-Duty Harlan - 8200 lbs (3719 kg) Load Capacity | Heavy-Duty Harlan with 1 1/8" Kingpin | Front and Rear: Leaf Springs | Three-tier Hitch with 1 3/4" pin (other hitch options avail) | Front: 6.50 x 10 Dual Rear: LT215/85R x 16 |
| Engines | Transmission | Electrical | Cooling | Steering System |
| Latest Model US/Euro Emission Diesel, Gasoline, LPG | Automatic Industrial | 12V System | Liquid cooled radiator with integrated transmission cooler | Power Assist or Hydrostatic |
| Service Brakes | | | | Park Brake |
| Hydraulic/Hydraulic, dual rear disc with optional front brakes | | | | Mechanical Drum, lever activated |

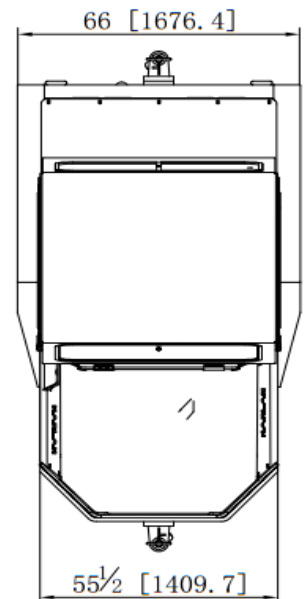
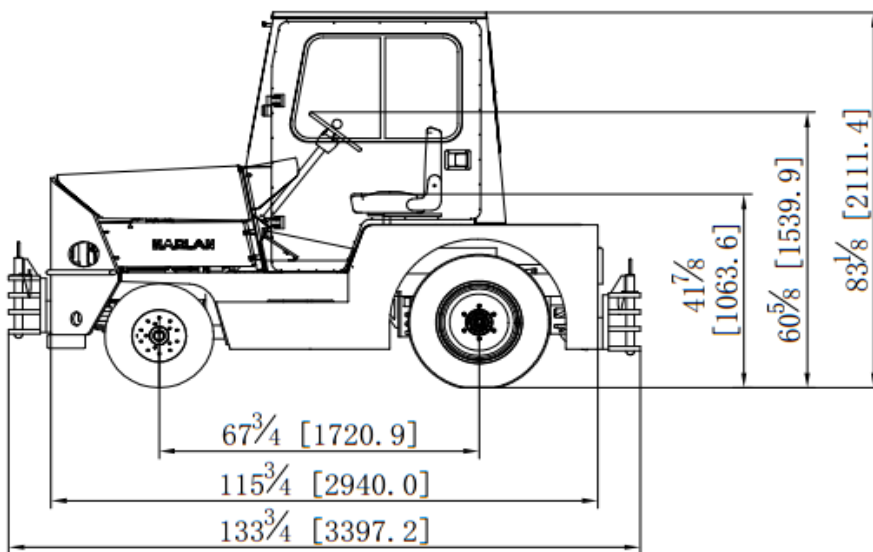

27 Stanley Road * Kansas City, KS * 66115 * USA
913-342-5650 * 800-255-4262 * Fax 913-321-5802
www.harlan-corp.com